



Smart solutions.
Strong relationships.

Small Size **Big** Returns

Emotron AC drives



emotron

DEDICATED DRIVE



A CG Product

About CG

CG Power and Industrial Solutions Limited (CG) is a pioneer in modern technology in electrical field which offers complete solutions for generation, transmission and distribution of energy by supplying globally recognized high-tech products delivering elevated efficiency and robustness. Since its inception, CG has been synonymous with electricity. In 1875, a Crompton 'dynamo' powered the world's very first electricity-lit house in Colchester, U.K. CG India operations were established in 1937, and since then the company has retained its leadership position in the management and application of electrical energy.

About CG Drives & Automation Division

CG acquired Emotron, a Sweden based technological company in 2011 and established CG Drives & Automation (D&A) as an entity. Emotron is not only a technology leader in Europe but also a pioneer in AC Drive technology worldwide with an existence of more than 40 years. With this acquisition, CG D&A offers low voltage AC Drives, Soft Starters, Shaft Power Monitor, Solar Drives, PLC and HMI with "EMOTRON" as a brand name well accepted in India and world wide. CG D&A has its state-of-the-art Engineering centres in Germany and Netherlands and two manufacturing facilities with in-house capabilities in India and Sweden. CG Emotron is an ISO 9001 : 2015, ISO 14001 : 2015 & BS OHSAS 18001 : 2007 Company.



Optimized operation and full control

Product Gallery



FDU / VFX



Flowdrive



TSA Softstarter



MSF Softstarter



VSR



Shaft Power Monitor



VSX



VSM



VSE



VSS



HMI & PLC



Drive Panel



Smart drive solutions

based on strong relationships

CG Drives & Automation offers complete drive solutions that ensure the safe and cost-efficient operation of demanding industrial applications. We provide smart solutions to users, operators, system integrators and OEMs around the world, wherever there are demanding applications, like for cranes, water handling systems and material handling systems.

We put all our energy into saving yours

At CG Drives & Automation, we use our know-how to create technical solutions that fit your requirements and our personal commitment to make them work in practice on your site, with your personnel.

Simplicity and reliability are the keywords applying to our products and solutions, as well as the service and support that our committed professionals provide. This saves you energy sense of the word!

New Arrivals

CG Drives & Automation, based on its 40 years of experience has now offered more valuable products to its portfolio. The new range of Emotron VSX / VSM Drives are compact, easy to install and provide a user-friendly setup which allows your system to be operational in less time. And with Programmable Logic Control (PLC) and Human Machine Interface (HMI), CG D&A has now become the complete Automation solution provider.

The new products range include:

- **VSX - High Performance Dynamic AC drives**
- **VSM - Compact Machinery AC Drives**
- **EmoLog - Programmable Logic Control**
- **EmoSmart - Human Machine Interface**

Emotron VSX



Emotron VSX Series Drives offer customised solutions for your required application in an incredibly compact design with technologically advanced package capable of driving Induction and Permanent magnet motor. The LCD graphical display offers user-friendly interface and set up will have your system up and running in time.



Range : 0.75 kW to 22 kW

Current : 2.5 Amp to 45 Amp

Voltage : 3 Phase 380 to 480 VAC/50Hz



Unique Features

- LCD graphical display with Oscilloscope feature as standard
- Optimized and compact structural design, leading technology platform
- Strong overload capability with 200% of rated load for 1 sec
- High-speed pulse input and output up to 100 KHz
- Compatible for Induction Motor and Permanent Magnet Motor
- V/F fully separated and semi-separated operation
- Built-in PLC Logic Functions, Virtual Digital I/Os with multi Logic functions, timer and comparators
- Built-in C3 Class EMC Filter
- EmoWizard tool for convenient debugging

Benefits

- Excellent performance with high start torque characteristic
- Robust Drive with conformal coated boards enables application in hot and humid climate
- Efficient cooling, improved reliability with independent air duct design

Applications

Fan, Pump, Blower, Crusher, Crane Hoist, Feeders Extruder and many more.

Emotron VSX, 3-phase Supply $U_n = 415\text{ V} \pm 20\%$, IP20

Model	Normal Duty (120%, 1min every 10min)			Heavy Duty (150%, 1min every 10min)			High Overload ability		Weight kg	Dimensions [W*H*D] mm,
	P nom [kW]	I nom [A]	I max * [A]	P nom [kW]	I nom [A]	I max * [A]	I max (180%, 10s)	I max (200%, 1s)		
VSX48-003-20CEB	1.5	4.2	5.0	0.75	2.5	3.8	4.5	5	1.45	80X200X170
VSX48-004-20CEB	2.2	5.5	6.6	1.5	4.2	6.3	7.6	8.4		
VSX48-006-20CEB	3.7	9.5	11.4	2.2	5.5	8.3	9.9	11		
VSX48-009-20CEB	5.5	13	15.6	3.7	9.5	14.3	17.1	19	2.5	116.6X186.6X175
VSX48-013-20CEB	7.5	17	20.4	5.5	13	19.5	23.4	26		
VSX48-017-20CEB	11	25	30	7.5	17	25.5	30.6	34	3.5	146X249X181.7
VSX48-024-20CEB	15	32	38.4	11	25	37.5	45	50		
VSX48-032-20CEB	18.5	37	44.4	15	32	48.0	57.6	64	6.45	198X300X189.7
VSX48-038-20CEB	22	45	54	18.5	37	55.5	66.6	74		
VSX48-045-20CEB	30	57	68.4	22	45	67.5	81	90		

Emotron VSM



Emotron VSM series drive offers more compact design with several advanced features. The compact design offers easy, flexible and user friendly installation which allows your system to be operational in no time. Emotron VSM offers reliable and cost efficient solutions for various variable and constant torque applications.

Range : 0.75 kW to 4 kW

Current : 2.5 Amp to 9.5 Amp

Voltage : 3 Phase 380 to 480 VAC/50Hz



Unique Features

- Optimized and compact structural design, leading technology platform
- Standard LED display
- Supports both Induction Motor and Permanent Magnet Motor
- Heavy duty Drive for various applications
- Built-in brake chopper
- High-speed pulse input
- Strong overload capability with 200% of rated load for 1 sec
- Built-in PLC Logic Functions, Virtual Digital I/Os with multi Logic functions, Timer and comparators
- Built-in C3 Class EMC Filter
- EmoWizard tool for convenient debugging

Benefits

- Excellent performance with high start torque characteristic
- Efficient cooling, improved reliability with independent air duct design

Applications

Pump, Fan, Blower, Conveyors, Crane and Damper Control

Emotron VSM, 3-phase Supply $U_n = 415\text{ V} \pm 20\%$, IP20

Model	Heavy Duty (150%, 1min every 10min)			High Overload ability		Weight kg	Dimensions [W*H*D] mm,
	P _{nom} [kW]	I _{nom} [A]	I _{max} * [A]	I _{max} (180%,10s)	I _{max} (200%,1s)		
VSM48-003-20CEB	0.75	2.5	3.8	4.5	5	0.85	75X150X117
VSM48-004-20CEB	1.5	4.2	6.3	7.6	8.4		
VSM48-006-20CEB	2.2	5.5	8.3	10	11	1.35	93X171X130
VSM48-009-20CEB	3.7	9.5	14.3	17	19		

	Parameter	VSX	VSM
Standard Specifications	Mains voltage:	3 Phase 415 Volt (±20% continues voltage fluctuation)	3 Phase 415 Volt (±20% continues voltage fluctuation)
	Mains frequency:	50/60 Hz, tolerance ±5%	50/60 Hz, tolerance ±5%
	Mains voltage imbalance:	max. +3.0% of nominal phase to phase input voltage.	max. +3.0% of nominal phase to phase input voltage.
	Input power factor (cos ϕ) :	0.97	0.97
	Output voltage:	0–Mains supply voltage	0–Mains supply voltage
	Output switching frequency:	0.7 kHz ~ 16 kHz	0.7 kHz ~ 16 kHz
	Efficiency at nominal load:	Rated power ≥ 93%	Rated power ≥ 93%
	Degree of Protection	IP20	IP20
	Overload Capacity	Normal Duty (120%,60s every 10 min) Heavy Duty (150%, 60s every 10 min) High Overload (180% 10sec, 200% 1 sec)	Heavy Duty (150%, 60s every 10 min) High Overload (180% 10sec, 200% 1 sec)
	Operator	LCD detachable	Built in LED (LED detachable optional)
	EMC-filter C3	Built In	Built In
Control Details	Control characteristics		
	Control Method	1:50 (V/f control) 1:100 (sensor-less vector control 1) 1:200 (sensor-less vector control 2)	1:50 (V/f control) 1:100 (sensor-less vector control 1) 1:200 (sensor-less vector control 2)
	V/f patterns	V/f control Sensor-less vector control 1 Sensor-less vector control 2	V/f control Sensor-less vector control 1 Sensor-less vector control 2
	Range of speed control	0 to 600 Hz	0 to 600 Hz
	Output frequency Resolution	0.01Hz	0.01Hz
	Speed control accuracy	± 0.5%(V/f Control) ±0.2%(Vector control 1&2)	± 0.5%(V/f Control) ±0.2%(Vector control 1&2)
	Accel /Decl Time	0-6000 S	0-6000 S
	Starting torque	0.5 Hz 180% (V/f, Vector control 1) 0.25 Hz 180% (vector control 2)	0.5 Hz 180% (V/f, Vector control 1) 0.25 Hz 180% (vector control 2)
	Torque response	< 10ms (sensor-less vector control 1, 2)	< 10ms (sensor-less vector control 1,2)
	Motor types	IM, PMSM	IM,PMSM
Built in Braking Chopper	DC brake start frequency: 0.00~600.00Hz DC brake time:0.0s~10.0s DC brake current:0.0%~150.0%	DC brake start frequency: 0.00~600.00Hz DC brake time:0.0s~10.0s DC brake current:0.0%~150.0%	

	Parameter	VSX	VSM
Interface	Control signal inputs:		
	Analogue input (differential)	2 channels up to 2.2kW , 3 Channels above 2.2kW	2 Channels
	Analogue Voltage/current:	0-10 V/0-20 mA via decided by toggle switches	0-10 V/0-20 mA via decided by toggle switches
	Max. input voltage:	10 V/25 mA	10 V/25 mA
	Input impedance:	250k Ω _i (voltage), 250 Ω _i (current)	250 k Ω _i (voltage), 250 Ω _i (current)
	Digital Input:	5 Channels up to 2.2kW (NPN or PNP) 7 Channels above 2.2kW (NPN or PNP)	5 Channels (NPN or PNP)
	Input voltage:	24VDC	24VDC
	Max. input voltage:	9V~30V VDC, 0 -200 Hz, Impedance:2.4k	9V~30V VDC, 0 -200 Hz, Impedance:2.4k
	Pulse input	Maximum input frequency: 100 kHz	Maximum input frequency: 100 kHz
	Signal delay:	≤ 8 ms	≤ 8 ms
	Control signal outputs:		
	Analogue output:	2 Channel	1 Channel
	Output voltage/current:	0-10 V/0-20 mA/ 4 to 20 mA	0-10 V
	Output impedance:	≥ 10 k Ω _i (voltage); 200 Ω _i - 500 Ω _i (current)	≥ 10k Ω _i (voltage); 200 Ω _i - 500 Ω _i (current)
	Maximum load impedance for current	500 Ω _i	500 Ω _i
	Hardware accuracy:	1% Fsd	1% Fsd
	Digital output:	1 Channel up to 2.2kW 2 Channels above 2.2kW	1 Channels
	Output voltage:	24 VDC, 50 mA, Pulse output (0-50kHz)	24 VDC, 50 mA
	Short-circuit current:	100 mA max (together with +24 VDC)	100 mA max (together with +24 VDC)
	Relays	2 (NO/NC)	1 (NO/NC)
	Contacts	250 VAC/3A or 30 VDC/3A	250 VAC/3A or 30 VDC/1A
	References		
	+10VDC	10 VDC ±3% @10 mA Short-circuit current +25 mA max	10 VDC ±3% @10 mA Short-circuit current +25 mA max
	+24VDC	+24 VDC Short-circuit current +200 mA max	+24 VDC Short-circuit current +200 mA max
	Programming interface	PC Software	PC Software
	Communication Support		
RS232/RS485 Isolated	Built In	Built In	
Profibus -dp	Optional	Optional	

Technical Specification

	Parameter	VSX	VSM
Environment	Environmental conditions - Operation		
	Cooling method	Forced air cooling	Forced air cooling
	Nominal ambient temperature	-10 °C~50 °C with derating max 60 °C	-10 °C~50 °C with derating max 60 °C
	Relative humidity according to IEC 60721-3-3	0-96%, no condensation	0-96%, no condensation
	Contamination, according to IEC 60721-3-3	No electrically conductive dust allowed. Cooling air must be clean and free from corrosive materials. coated boards.	No electrically conductive dust allowed. Cooling air must be clean and free from corrosive materials. coated boards .
	Vibrations	Less than 5.9m/s ² (0.6g)	Less than 5.9m/s ² (0.6g)
	Altitude	0-2000 m(0-3280 ft). De-rate 1% for every 100m when the altitude is above 1000 meters	0-2000 m(0-3280 ft). De-rate 1% for every 100m when the altitude is above 1000 meters
	Environmental conditions - Storage		
	Temperature	-20°C to +70°C	-20°C to +70°C
	Atmospheric pressure	86-106kPa (12.5-15.4PSI)	86-106kPa (12.5-15.4PSI)
	Relative humidity according to IEC 60721-3-1	5~95%, no condensation	5~95%, no condensation
	Operation at higher temperature (above 50°C ambient temperature.)	-1% / degree Celsius to max +15 °C (max 60 °C)	-1% / degree Celsius to max +15 °C (max 60 °C)



Terminal Wiring Details – VS Series Product

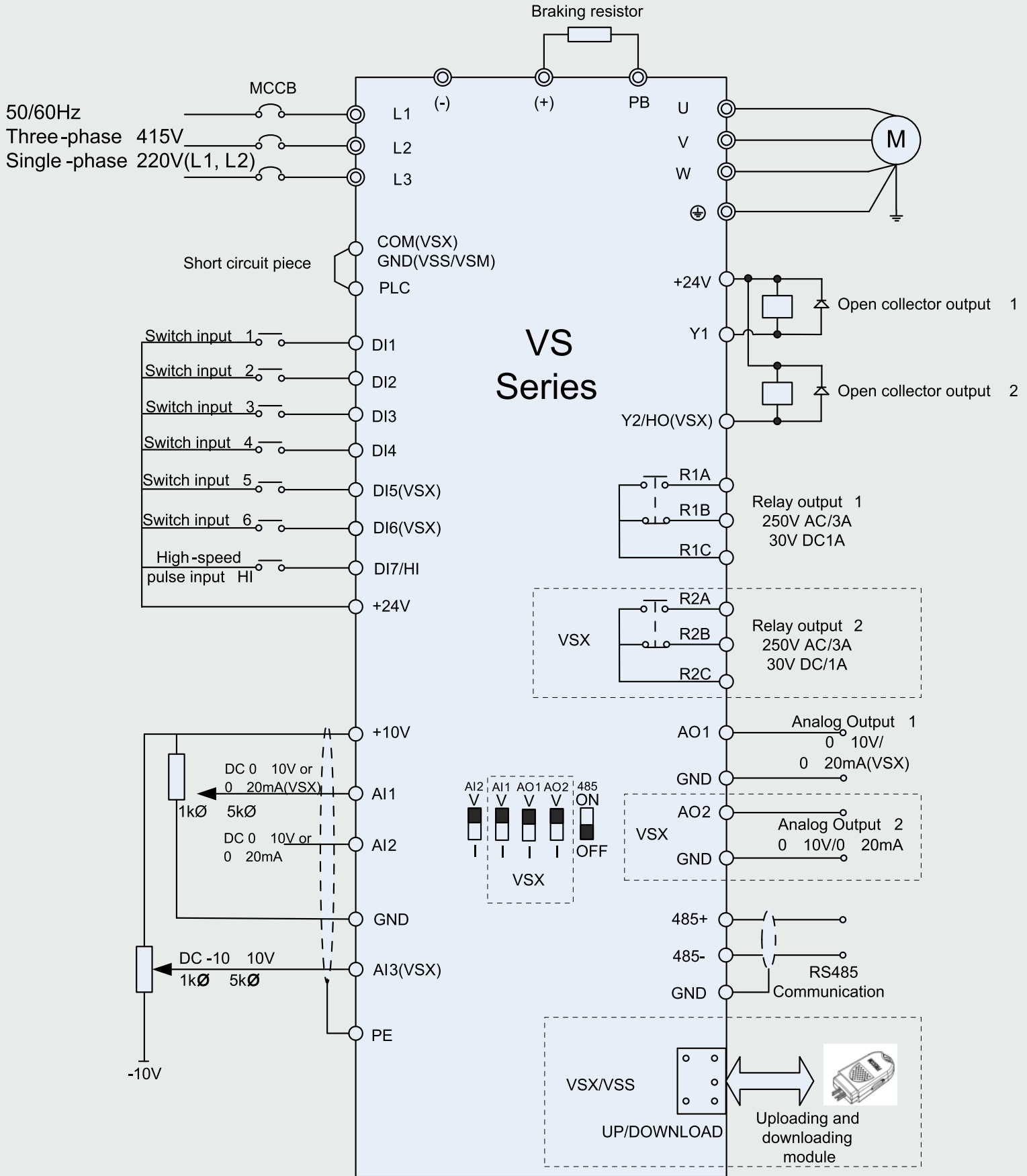

Human Machine Interface



Emotron EmoSmart series HMI is based on a modern, powerful & user friendly design having high quality display resolution, large memory and a powerful configuration that can easily achieve the human-machine interaction in various fields and industrial automation.

Unique Features

- Higher computing performance with high speed processor
- High resolution and high contrast with reliable touch panel
- The built-in stereo amplifying speaker provides efficient alarm notification

Benefits

- Mechanism design breakthrough. The front panel has acquired the IP65 waterproof certificate & back panel is IP20.
- ABS Black/Gray enclosure for greater vibration resistance and higher tolerance for ambient environment compared with other enclosures.
- This system allows users to assign authority levels & register passwords to set permissions for different user groups for security control.

Peripheral Interfaces

- Supports SD Card
- Supports USB Host 2.0 Ports & USB Client 2.0 Ports
- Built-in communication ports: RS232/422/485
- Built-In ethernet ports in 7 inch (as optional)

Selection Guide & Specifications

Model	Display Size	Resolution	Processor	Programming Port	Communication Ports	Power Supply	Dimension
HMI004	4.3 Inch	480*272	32-bit 300MHz RISC	Micro USB	COM1:RS422 / 485 COM2:RS232	DC 24V	142 X 86 X 30.3 (WXHXD)
HMIWE07	7.0 Inch	800*480	32-bit 300MHz RISC	USB Client	COM1: RS232/422/485	DC 24V	201 X 146 X 36 (WXHXD)
HMI007	7.0 Inch	800*480	Cortex A8 600Mhz	USB Client	COM1: RS232/422/485 COM2: RS232/485 Ethernet	DC 24V	201 X 146.6 X 36.5 (WXHXD)

Technical Specification

Parameters	EmoSmart		
	HMI0007	HMIWE07	HMI0004
Programming Software	EmoSmart	EmoStudio	
Display Size	7 Inch		4.3 Inch
Resolution	800x480		480x272
Colours	16000K	65535	
Contrast	(500:1)		
Brightness	300cd/m2	250cd/m2	450cd/m2
Backlight Type	LED		
Backlight Life	50,000Hrs		
Touch Panel Type	High precision four-wire resistive		
CPU	600Mhz Cortex A8	32-bit 300Mhz RISC	
Memory	128MB		
RAM	128M DDR3	64M DDRAM	
Program Upload/Download	USB-B		Micro-USB
COM Port	COM1 & COM2	COM1	COM1 & COM2
Ethernet	Yes		
CAN Bus	No		
Profi-Bus/Profi-Net	No		
Pen drive Support	Yes		
Power Supply	24Vdc		
Power Consumption	<10W	<5W	
COM1	RS232/422/485		RS422/485
COM2	RS232/485		RS232
Built-in RTC		Yes	
Enclosure		ABS	
Protection		IP65 Front Panel	
Cooling		Air Cooling	
Humidity Condition	10-90% RH	10-85% RH	
Seismic Resistance	10-25Hz (X,Y,Z direction 2G/30 minutes)		
Operating Temperature	(-10°C to 60°C)		
Storage Temperature	(-30°C to 70°C)	(-20°C to 70°C)	
Dimension (Outer)	201x146.6x36.5 (WxHxD)mm	201x146x36 (WxHxD)mm	142x86x30.3 (WxHxD)mm
Compliances	CE		

Programmable Logic Controller



Emotron EmoLog series is a high performance compact type Programmable Logic Controller (PLC) for your automation process. It can be widely applied in manufacturing industries including SPM, textile, chemical fiber, machine tool, cables, food and beverages, packaging, plastic steel, construction machinery, air conditioner, elevator printing and many more.

Unique Features

- STM32 high-performance MCU platform
- Available 14 & 24 I/Os CPUs with Transistor & relay configuration
 - Built in 2 high speed digital inputs Max. 200kHz frequency
 - Built in pulse output type PWM/PTO
- Built-in RS422/RS485 communication port
- Program memory up to 128Kb
- Supports 64k-step ladder
- Built - in real time clock
- Operating temperature 55°C

Benefits

- Configure up to 256 I/O points
- Support ladder and instruction list programming
- Support optional board up to 2 no's (For AI/AO, Ethernet Port)
- Compatible for N: N protocol and RS485 communication port, you can create a network of up to 8 CPU
- Reliable and stable high speed micro USB port for programming download/monitor
- User friendly programming software

Selection Guide & Specifications

Model	Type	Total I/Os	DI	DO	Com	High Speed Input (200kHz)	High Speed Input (100kHz)	Ex Board (optional)	Expand able	System Storage	Programing Port	Power Supply	Dimension (W*H*D) mm
PLC0806R	Relay	14	8	6	Com1-RS422 Com2-RS485	2	0	1	NO	16K	micro USB	24VDC	75x107x87
PLC0806T	Transistor	14	8	6	Com1-RS422 Com2-RS485	2	2	1	NO	16K	micro USB	24VDC	75x107x87
PLC1212R	Relay	24	12	12	Com1- RS422/RS485 Com2-RS485	2	0	1	Yes - Upto 16	64K	micro USB	24VDC	137x107x87
PLC1212T	Transistor	24	12	12	Com1- RS422/RS485 Com2-RS485	2	2	1	Yes - Upto 16	64K	micro USB	24VDC	137x107x87

Technical Specification

Parameters	EmoSmart	
	PLC0806T/R	PLC1212T/R
Programming Software	EmoLog	
Programming Language	Ladder, Instruction List (IL)	
Digital Input	8	12
Digital Output	6	12
Input/output Type	Relay (R) & Transistor (T)	
High Speed Input (HSC)	2 No (X0, X1 both -200 KHz)	
High Speed Output	2 No (Y0, Y1 both 100 KHz) Available in Transistor	
Max No of Expansion module Support		16
Max No of Ex- Board Support	1	
Max No of digital Input		256 (Including PLC Input)
Max No of digital Output		256 (Including PLC Output)
Max No of Analog Input	4 Channels	64 (Excluding CG Ex-Board)
Max No of Analog Output	4 Channels	64 (Excluding CG Ex-Board)
Program Upload/Download/ Monitor Port	Micro-USB	
No of Communication Port	2	
Communication Type	Modbus RTU/ASCII	
COM Port Configuration	COM1: RS422	COM1: RS422/485
	COM2: RS485	COM2: RS485
Maximum Program Size	16K Step	64K Step
Real Time Clock	Yes	
Protection	IP20	
Max Scan Time	Basic Instruction : 0.06μs	
	Applied Instruction: 0-10ms	
Operating Temperature	0—50°C	
Storage Temperature	-20—70°C	
Compliance	CE	

EMOLog - Ex Board

Model	Description	Type	PLC0806T/R	PLC01212T/R
EX-2ADI2DAI	2 Channel analog input. (Current 4 to 20mA). 2 Channel analog Output. (Current 4 to 20mA).	Analog Input/ Analog Output	X	√
EX-2ADI	2 Channel analog input. (Current 4 to 20mA)	Analog Input	√	√
EX-2ADV2DAV	2 Channel analog input. (Voltage -10 to 10V). 2 Channel analog Output. (Voltage -10 to 10V).	Analog Input/ Analog Output	X	√
EX-2ADV	2 Channel analog input. (Voltage -10Vdc to +10Vdc)	Analog Input	√	√
EX-2DAI	2 Channel analog Output. (Current 4 to 20mA)	Analog Output	√	√
EX-2DAV	4 Channel analog Output. (Voltage -10Vdc to +10Vdc)	Analog Output	√	√
EX-2PT2ADV	2 Channel Platinum temperature Input. PT100, 3 Wire & 2 Wire; 2 Channel analog input Voltage (-10Vdc to +10Vdc).	Temperature Input/ Analog Input	X	√
EX-2PT2DAI	2 Channel Platinum temperature Input. PT100, 3 Wire & 2 Wire; 2 Channel analog output Current 4mA to 20mA.	Temperature Input/ Analog Output	X	√
EX-2PT2DAV	2 Channel Platinum temperature Input. PT100, 3 Wire & 2 Wire; 2 Channel analog output Voltage -10Vdc to +10Vdc.	Temperature Input/ Analog Output	X	√
EX-2PT	2 Channel Platinum temperature Input. PT100, 3 Wire & 2 Wire	Temperature Input	√	√
EX-2PTS	2 Channel Platinum temperature Input. PT100, 3 Wire & 2 Wire	Temperature Input	√	√
EX-2RS485	2 Channel RS485.	Communication	√	√
EX-2TC2DAI	2 Channel Thermo Couple Input (J & K type 2 wire) 2 Channel analog output Current (4 to 20mA).	Temperature Input/ Analog Output	X	√
EX-2TC	2 Channel Thermo Couple Input (J & K type 2 wire).	Temperature Input	√	√
EX-4ADI	4 Channel analog input. (Current 4 to 20mA)	Analog Input	X	√
EX-4ADV	4 Channel analog input. (Voltage -10Vdc to +10Vdc)	Analog Input	X	√
EX-ETH	Modbus TCP. Support in PLC1212T/T Only. Max 8 devices can be connected in one Ethernet Board.	Communication	X	√



EmoLog Expansion Board

Model	Description	Type	PLC0806T/R	PLC01212T/R
EXP-16EX	16 Channel Digital Input Transistor. DC 24V, PNP/NPN Type.	Digital Input	X	√
EXP-16EYR	16 Channel Digital Output Relay. Less than 30VDC.	Digital Output	X	√
EXP-16EYT	16 Channel Digital Output Transistor. DC 5V to 30V. NPN Type. Negative output	Digital Output	X	√
EXP-1WT	1 Channel 24 bit resolution weight input.	Weight	X	√
EXP-1WT-L	1 Channel 18 bit resolution weight input. Low price than EX-1WT.	Weight	X	√
EXP-2WT	2 Channel 24 bit resolution weight input.	Weight	X	√
EXP-2WT-L	2 Channel 18 bit resolution weight input. Low price than EX-2WT.	Weight	X	√
EXP-4AD	4 Channel Analog Input. (-10vto+10v) and/or 4mA-20mA, -20mAto+20mA.	Analog Input	X	√
EXP-4DA	4 Channel Analog Output (-10v to +10v) and/or -20mA to +20mA.	Analog Output	X	√
EXP-4LTC	It's a temperature control module having 4 channel Thermo Couple Input gives 4 Channel transistor output (OC) with PID control.	Temperature Control	X	√
EXP-4PGA	Enhanced 4 Channel Pulse Output. Maximum 200Khz	Pulse Output	X	√
EXP-4PGB	Basic 4 Channel Pulse Output. Maximum 200Khz	Pulse Output	X	√
EXP-4PT	4 Channel Platinum temperature Input. Type PT100 3 wire (100 Ohm).	Temperature Input	X	√
EXP-4TC	4 Channel Thermo Couple Input. Type J & K.	Temperature Input	X	√
EXP-8EX	8 Channel Digital Input Transistor. DC 24V, PNP/NPN Type.	Digital Input	X	√
EXP-8EYR	8 Channel Digital Output Relay. Less than 30VDC.	Digital Output	X	√
EXP-8EYT	8 Channel Digital Output Transistor. DC 5Vto30V. PNP Type. Negative output	Digital Output	X	√
EXP-8iTC	8 Channel Thermo Couple Input. Type K, S, E, N, B, T, J and R.	Temperature Input	X	√

Applications

CG Drives & Automation offers complete drive solutions that ensure the safe and cost-efficient operation of demanding industrial applications. We provide smart solutions to users, operators, system integrators and OEMs around the world, wherever there are demanding applications, like for cranes, water handling systems and material handling systems.

Application	VFX	FDU	VSM	VSX	VSS	VSR	VSE	M20	TSA/MSF
Pump		✓	✓	✓	✓			✓	✓
Solar Pump						✓		✓	
Fan		✓	✓	✓	✓			✓	✓
Blower		✓	✓	✓	✓			✓	✓
Conveyors	✓		✓	✓	✓			✓	
Compressor	✓	✓							
Wire Drawing Machine	✓								
Grinding Machine	✓			✓					
Winders	✓								
Crane Hoisting	✓			✓					
Crane Traverse	✓		✓	✓					
Agitators	✓			✓					
Extruders	✓			✓					
Washing Machine	✓		✓	✓					
Rubber Mill	✓			✓					
Sugar Mill	✓			✓					
HVAC		✓							
Damper Control		✓	✓	✓					
Lifts Door Control			✓	✓	✓				
Lifts & Escalators							✓		
AHU		✓							
Ball Mill	✓								
Textile Machinery	✓								
Centrifuge	✓								
Spinning Machine	✓								
Rotary Klins	✓								
Printing					✓				
Crushers	✓								✓
Press				✓					
Plastic Machinery	✓								
Packaging	✓								
Mixers	✓								
Pulper	✓								
Rubber Machinery	✓								
Machine Tools	✓			✓					
Material Handling	✓		✓	✓	✓				
Cheese Winder					✓				
Incense Sticks					✓				
Auto Trolley Printing				✓					

EmoWizard software helps in easy commissioning and troubleshooting of VSX and VSM series Drives with user-friendly tools for viewing, manipulating, and exchanging data with the drive. Statistics data can be plot with help of oscilloscope, drive control with control panel.

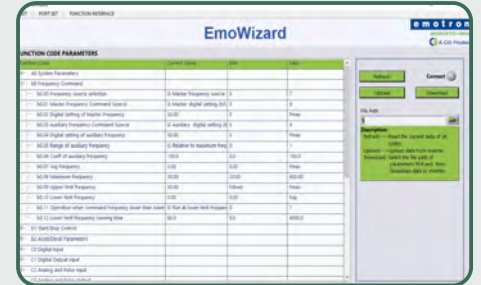

EmoSmart

- Programming software for EmoSmart series HMI
- User-friendly Programming Tool
- Varies level of user management

EmoStudio

- Programming software for EmoStudio series HMI
- Built-in video input display, moving picture
- Wide ranges of animations, charts, recipes, alarms available

EmoLog supports development of applications in Ladder & Instruction List.

- Programming software for micro series PLC
- Highly advanced programming interface
- Simplified network configuration



Registered Office

CG Power and Industrial Solutions Limited
CG House, 6th Floor, Dr Annie Besant Road, Worli, Mumbai 400 030, Maharashtra, India
Phone: +91 022 2423 7777

Manufacturing Location

CG Drives and Automation
Plot#9, MPAKVN, Phase-2, New Industrial Area, Mandideep 462 046, M.P.
Phone: 0748 0426427 / 440 / 441 / 456

CG Drives & Automation Sweden AB
Morsaregatan 12, Box 222 25
SE-250 24 Helsingborg, Sweden
Tel: +46 42 16 99 00

Regional Sales Office

North : 4th floor, Discovery Tower, Plot No. 17, Block A, Industrial Area, Sector 62, Noida,
Uttar Pradesh - 201301 | Phone : 0120-6861900
East : 50 Chowringhee Road, Kolkata 700 071, West Bengal | Phone : 033-22829681
West : 1st Floor, Kanjur Marg East, Mumbai 400 042 | Phone : 022-67558609
South: No.3-A, Dr. MGR Salai, Nungambakkam, Chennai 600 034 | Phone : 044-42247500

Email:

drives.mktg@cgglobal.com | drives.service@cgglobal.com

Our All India Service Center Toll Free No : 1800 267 0505

For more information visit:

www.cgglobal.com | www.emotron.com